

Modification the driver stage of SSPA UMTS module to 2320 and 2400 MHz



This manual concerns retuning the driver stage (MW71C2240N) of the UMTS power amplifier module to 2320 and 2400 MHz amateur bands. After modification, it is possible to obtain at least 35 W of output power, with 60 mW of input power.

Warning: Be especially careful not to expose your eyes to RF power - working amplifier must have the lid put on.

The modification of the module begin with the removal of almost all elements from the MW71C2240N input matching circuit (figure 1). Leave only the capacitor closest to the input.

Matching of the input can be achieved, depending on the module, by playing with only copper foil (snowflakes, figure 2) or by a combination of foil and a 0.47 pF capacitor (figure 3). In both cases, the width of the marked track should be narrowed by half. In place of the removed elements connected in series, connections with foil should be made.

The modification of the output consists in replacing the marked capacitor with new one 1 pF (case 0805). When the P1dB power is low (below 35W), improvement can be obtained by cutting a piece of the track in the output circuit or changing the 1 pF capacitor to a value in the range of 0.47 - 0.82 pF. See figure 2.

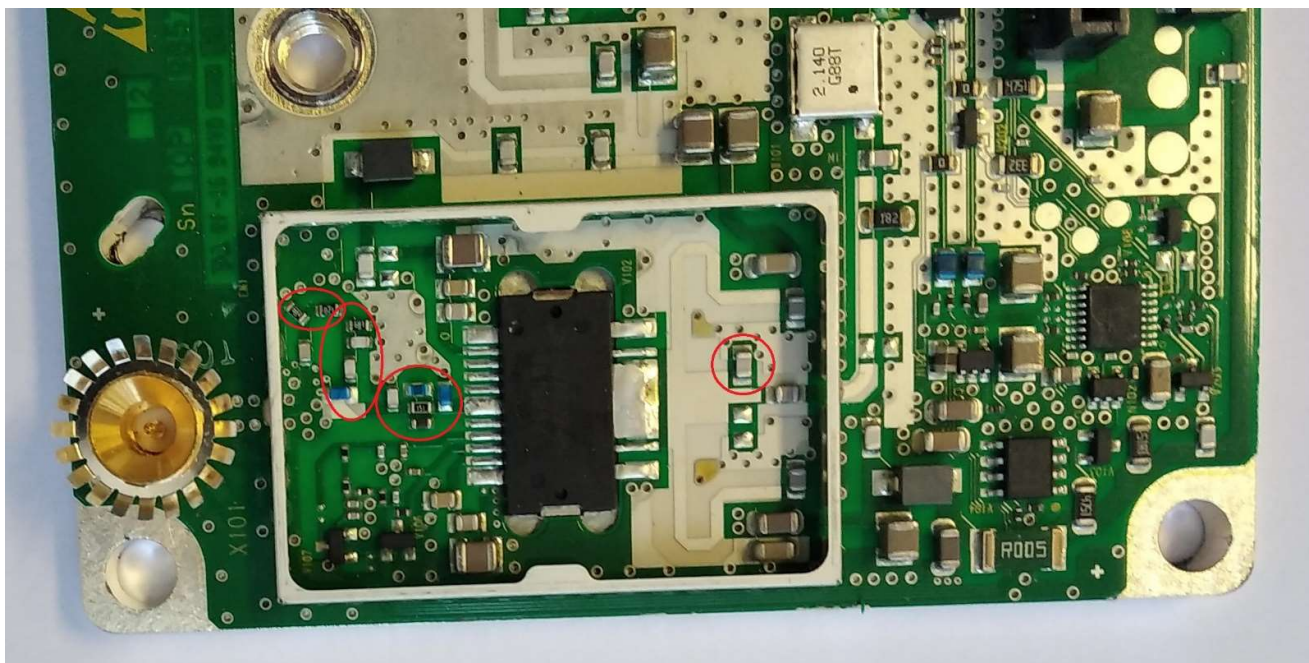

Figure 1. Marked elements to be removed

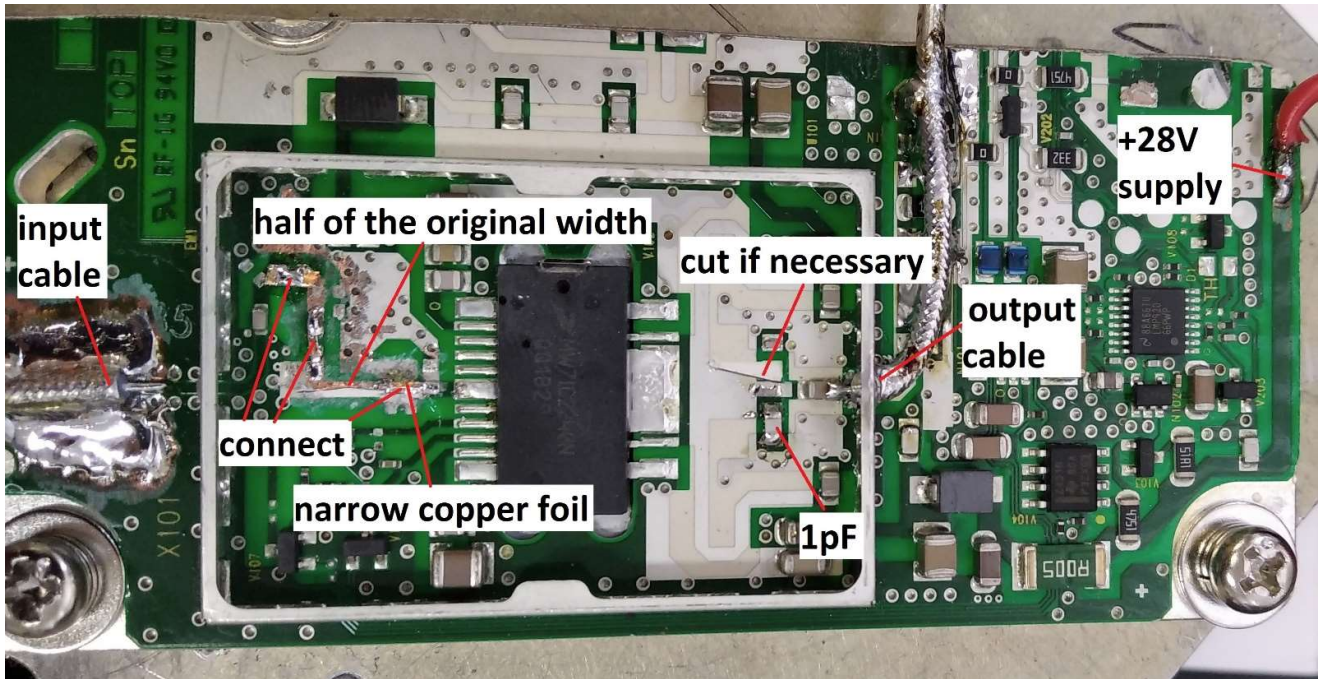

Figure 2. Modification of the module. Input matching achieved with copper foil only.

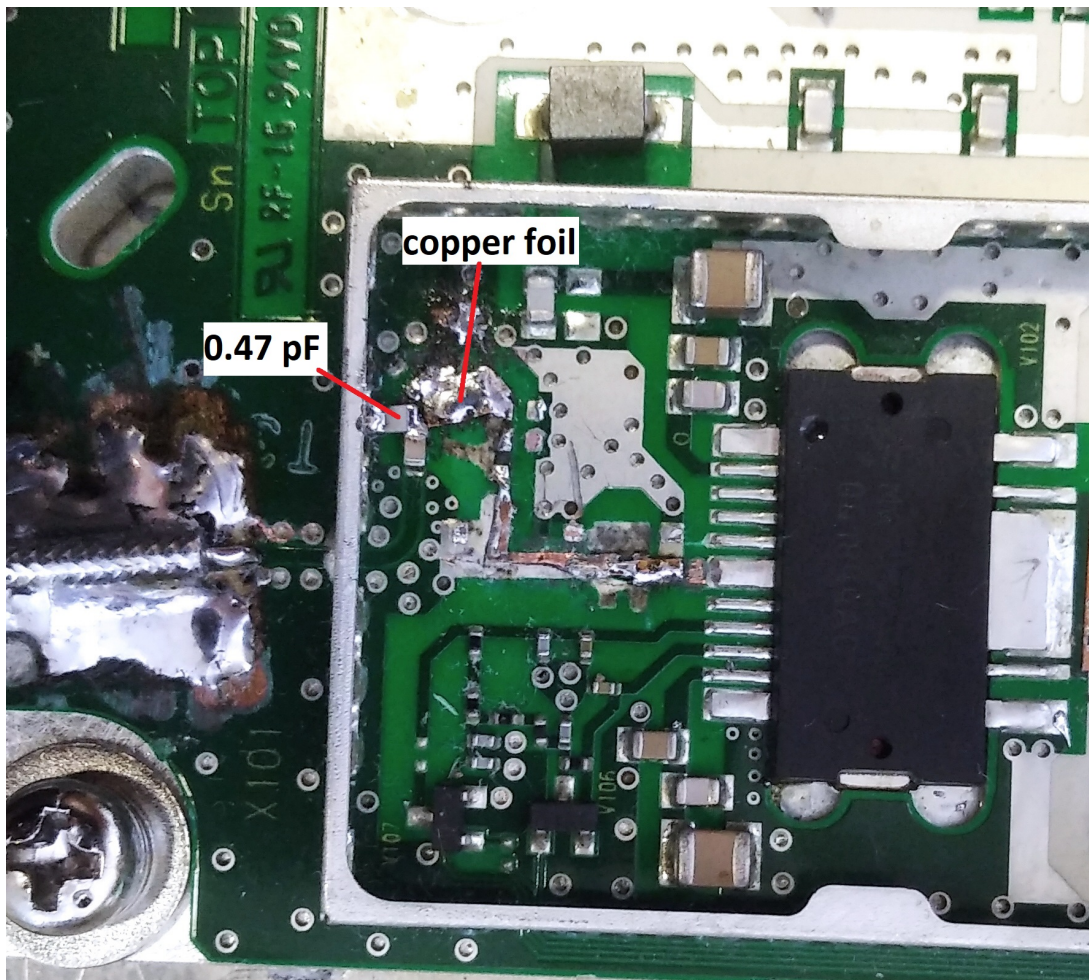

Figure 3. Input matching achieved by a combination of the 0.47 pF capacitor and copper foil.

The P-SMP input socket can be left or removed and in its place a cable with SMA plug should be soldered.

As for the output, cut the 50 ohm track going to the final stage and solder the cable with the SMA plug at this point. The track can be cut under the vertical part of shielding - this will facilitate connecting of the cable, as the cable braid can be then soldered to the shielding plate. For mechanical reasons, the output cable used, should have a diameter of approximately 2 mm. It must also be able to withstand a power of 40-50 W at 2320 MHz. A cable with teflon dielectric type can be used - flexible RG316 or semi-rigid UT086.

It is possible to cut off the unused part of the board as shown in the figure 4. However, be careful not to damage the elements next to the shielded part, as some of them are part of the Vgs1 and Vgs2 bias circuit of the MW71C2240N. If leave the board in its entirety, cut the track supplying +28 V to the final LDMOS transistor.

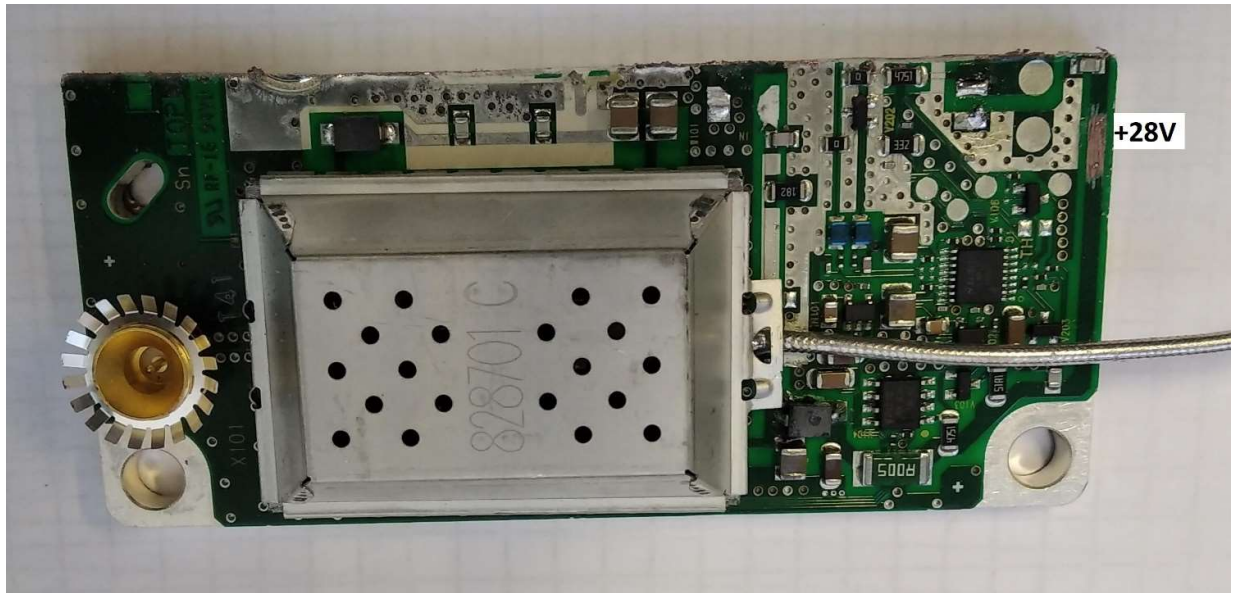

Figure 4. Power amplifier board after cutting off unused part.

According to the new procedure described above a few modules were modified. The following results were obtained (at 2320 and 2400 MHz):

- Input power 50 to 60 mW (+17 to +18 dBm)
- Output power (P1dB) 38 to 42 W
- Supply voltage + 28 V
- Idq 0.6 A
- I_{max} 3 to 3.5 A
- Input SWR 1.05 to 1.3